

# Modular Ice Machine (Head Only) Flake - 200kg/24h

| Ice Machines

Stainless steel construction for corrosion resistance and easy cleaning

Shapeless flake ice cools rapidly without harming delicate produce

Electric PCB controller for easy settings adjustment and monitoring

Fully compliant with Australian safety standards and regulations

Bromic Extra Care Warranty - 3 Years Parts, 1 Year Labour

Efficient cooling reduces ventilation clearance requirements for easier installation

Agion®-treated materials prevent bacteria growth for maximum hygiene

Head Only, Suitable storage bin: SB129, SB178, SB243. Sold separately.



## Modular Ice Machine (Head Only) Flake - 200kg/24h

Ice Machines

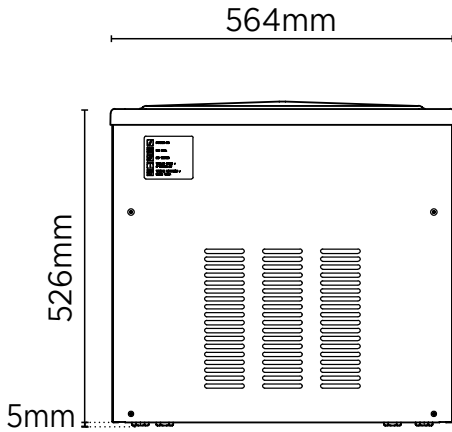

**FRONT VIEW**

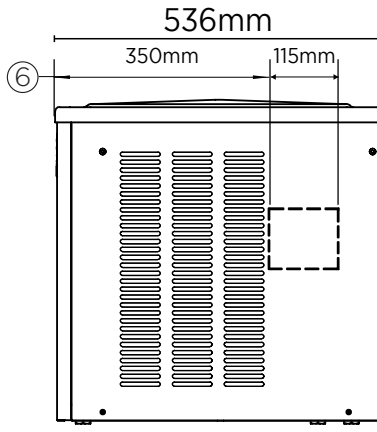

**SIDE VIEW**

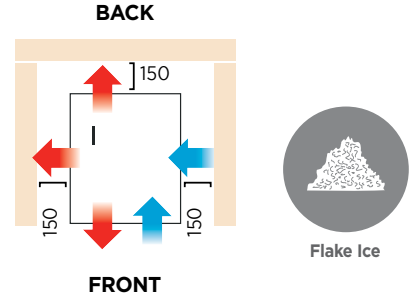

**FRONT**

**AIR COOLED MODELS**

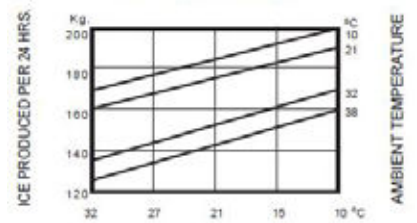

**WATER TEMPERATURE**

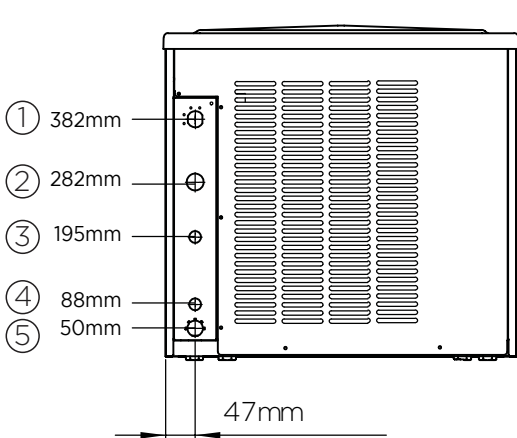

**REAR VIEW**

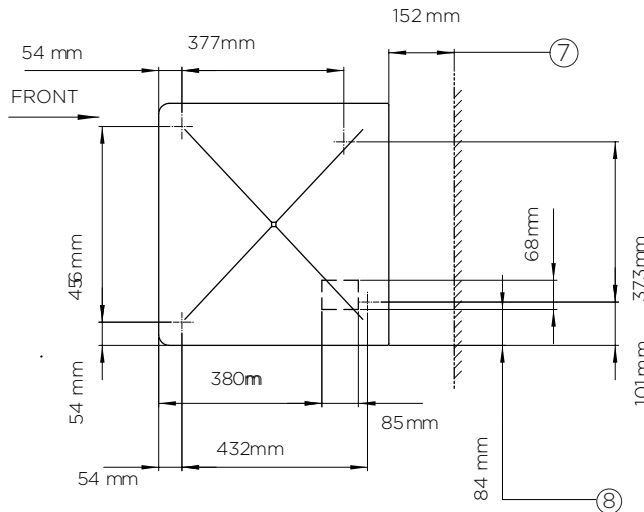

**TOP VIEW**

1. CORD SET
2. 3/4" GAS WATER INLET
3. 3/4" GAS WATER INLET WATER COOLED ONLY
4. 3/4" GAS WATER OUTLET WATER COOLED ONLY
5. Ø 21mm WATER OUTLET
6. ICE EXIT RIGHT PANEL SIDE
7. MIN. FOR UTILITY CONNECTIONS
8. ICE EXIT BOTTOM SIDE

### SPECIFICATIONS

Model	IM0200FM-NR
Part Number	3935195
Unit Weight	49kg
Packaged Weight	56kg
Ambient Temperature	43°C
Energy Consumption	15.2kWh/24h
Refrigeration Capacity	700W
Refrigerant	R290
Current	3.2A
Electrical Voltage	230V

Frequency	50Hz
Power Supply	Single Phase
Plug Supplied	1 x 10A
Plug Location	Rear, bottom left
Water Consumption	7.4L/h
Maximum Daily Production	200kg/24h
Ice Type	Flake
Storage Bin Compatibility	SB129, SB178, SB243
Warranty	3 Years Parts & 1 Year Labour Bromic Extra Care

### DIMENSIONS

External (mm)	
Width	564
Depth	536
Height	531
Packaged (mm)	
Width	630
Depth	610
Height	680

External height excludes legs  
Production is based on kg/24hr at 10°C air & 10°C water